

Editor: **Jamie Hart**

Ph: 084-220-0082

Email: jamie.hart@kingsley.co.za

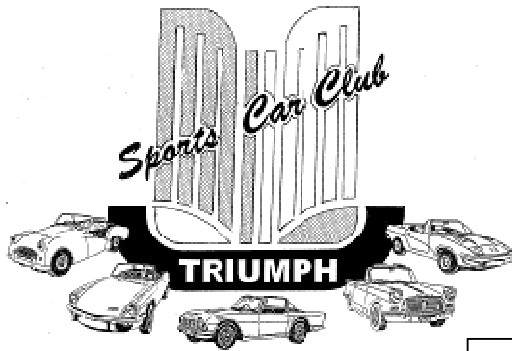

NEWSLETTER – June 2010

Chairman's Chat

The weather at this time of year is without doubt the Western Cape's biggest secret. Once more the sun shone on a good run to the Avontuur Wine Estate and also on our second Saturday noggin. See the report, but 22 members with 10 Triumphs was a great turnout and I am really pleased that as a club we are thriving as we go into the winter months instead of simply surviving. The June noggin promises to be another interesting one at Malcolm Uytenbogaardt's workshops.

Plans are progressing for the concours event which will be on Sunday 28th November. We are in discussion with the Protea Hotel at the Technopark just outside Stellenbosch who have excellent facilities where we may have exclusive use of a restaurant with stunning views for the whole morning finishing off with lunch. Cars will be displayed on an adjacent grassed area or in a reserved area of the car park. The next newsletter will contain the rules for concours and some 'must do's' as well as a couple of 'don'ts'. Have a critical look at your car now and note any little jobs needing done which would improve its presentation. I think the real trick here is not to leave it until the last minute. Please put this event in your diary as it promises to be a good day out. Anne is looking at some activity for the ladies during the morning who may not wish to assist in the cleaning of cars! There will be no obligation to enter your car in any competition and you may simply arrive in it and park up.

You will see later in this publication a list of events, other than noggins or runs, which takes us through the next 12 months. There is a lot on but we have taken the trouble this time to publish dates so that you can decide which ones are for you. Please pay particular attention to a couple of events which are overnight jaunts. The first is the 6th/7th November which is a club weekend away, destination to be confirmed and also 12th/13th February which is a trip to the Old Car Show in George to join up with our fellow clubs from Port Elizabeth and East London. A few of us did this for the last show and it was a great weekend both socially and in driving terms. By popular demand discussions are also under way with these clubs to have a rerun of a weekend in Plett which took place in June 2009. This is still work in progress so again, watch this space.

The bottom line is that it is good to see the cars being exercised and it is also good for them and you. The best tonic going! I do hope this inspires you to make these events if you possibly can.

There was an old advert which said 'clunk click every trip'. That is much nicer than saying 'belt up' but you get my meaning. Wear seatbelts ALL the time and drive safely.

Tom



Some of the members & cars that met at the NI Engen before leaving for Avontuur Wine Estate

Editor's desk

Many apologies for this being a relatively short newsletter, but I wanted to get the main events the club will be doing in the future out before we disappear for a few weeks. This way you can highlight those things you are interested in rather than saying "if only we had known!". I promise you that the July edition will be a bumper one, let's have some articles please!

Forthcoming Events - Please diarise!

Mid month run to Hillcrest Berry Farm - Sunday 13 June

This run is being organized by Laurie Gleeson. Please meet at the N2 Engen (please note this is the road to George!!!) at 9h00 for a 9h15 departure. Please confirm your attendance with Laurie by the 8th June, his number is 082 378 1522.

Patat Festival, Napier - Saturday 19 June

The MG Club in the Overberg has invited us to display our cars at the Patat Festival in Napier. They would like us there by 11am to participate in a classic car gathering until 3pm. During this time they will provide security for the cars and transport for us to take in the festival. Sounds like a fun winter day out if the weather is fair as the roads to Napier are fabulous. Contact Tom on 072 913 2392 if you are up for it.

Noggin - Saturday 26 June

The next noggin is at 10h00 on Saturday 26th June which will include a visit to the workshops of Malcolm Uytenbogaardt (and bacon rolls)! Malcolm has several interesting cars including a Spitfire. The facility also has a car lift available, for those that would like to examine the underside of their car. **The noggin will be held at the premises of Liftech, located on the corner of 1st and 4th Streets, Montague Gardens** (not the Parow Clubhouse). Details by SMS a few days before the event.

Major events for 2010 / 2011

Wheels and Whales	Hermanus	Sat 25 th September
Franschoek Motor Museum	Track day at Killarney	Sat 30 th October
Weekend away	Hermanus?	6 th / 7 th November
Classics in Hout Bay	Hout Bay primary school	Sun 21 st November
Classic Car Show	Timour Hall	Sun 23 rd January 2011
Springbok racing series	Killarney	Sun 7 th February 2011
George Old Car Show	George	12 th / 13 th February 2011
British Sports Car Tour		Sun 27 th March 2011
W/end P.E. and Border centres	Garden Route	June 2011?

Report backs

Report back on Mid month run to Avontuur Wine farm - Sunday 16 May

Thanks to Gerhard and Suzette Vorster for organizing this wonderful breakfast run to the Avontuur estate near Somerset West. We met at the Engen N1, yes some people managed the N2 Engen, and set off a bit later than anticipated due to latecomers! Instead of having the scenic route, we ended up going straight down the R44 as we had a time constraint before lunch was due to be served.

We had 13 cars in total and it was good to see so many of our long term members. A special mention to Ashley and Margie Ellis for coming from the south peninsula, and especially to Nick and Denise Joubert for coming all the way from Struisbaai in their (soon to be sold) red TR3. Glad you were able to find the farm from the N2 alright.



Breakfast was served on the terrace as it was such a great day with views across to Table Mountain and everyone seemed to have a wonderful time.

Report back on May Noggin - 29 May

The second Saturday morning noggin was again blessed by good weather which saw a strong turnout of 22 members and 10 Triumphs. There was an easy relaxed vibe with people wandering out into the sunshine through the 'garage' door on the end wall. Technical tips were exchanged in the car park over bacon rolls and coffee while Wilhelm Cool held a car boot sale of garage and woodworking tools before heading off to New Zealand.

Star of the day was a very patriotic Peter Du Sautoy who gave a fascinating presentation on his very well documented TR5. He had gone to some trouble in his preparation which included a video of him pouring champagne over the bonnet on the completion of restoration. Well done Peter and we witnessed another strong contender for the end of year Pride of Ownership event.



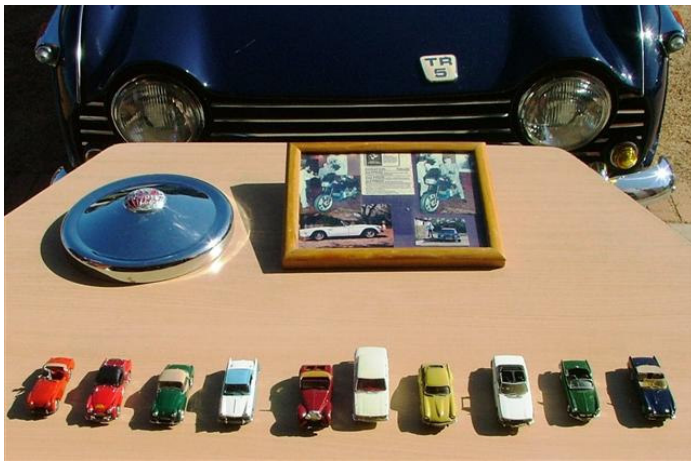

Peter has over the years collected models of virtually every Triumph he has owned, he also has a replica of the R5 hubcap that started his Triumph involvement all those years ago. The picture shown shows the history of how his R5 hubcap became a BMW motorcycle and eventually a Triumph TR5.

Peter giving his well presented 'One man and his Triumph' talk



Technical Tips

New (?) Publication on TR PI system by Peter du Sautoy

Towards the end of last year, "TRAction" published an advert for various Triumph related books including one simply listed as "Lucas PI Manual".

What appeared to be a PI problem ever since my recent engine overhaul brought the advert back to mind so I placed an order by e-mail. The price was £5 plus another £3 for postage and packaging and thanks to the TR Register's usual efficiency the booklet arrived at the Simon's Town Post Office in a remarkably short time.

It is a 32 page booklet with two 16 page sections headed "Part 1 - Description and Function of Petrol Injection System" and "Part 2 - Workshop Instructions"

Much of the content can be found in the various factory workshops and after market manuals but some items are more clearly described and there are one or two bits not seen elsewhere, as well as some interesting graphs. After studying the first part, I now have a very much improved idea of how the system functions particularly the mixture control, which has given some new thoughts on what could be wrong with my own system.

The "Workshop Instructions" section starts with a detailed exploded diagram of the metering distributor and control unit showing every single part, something I have never seen in any other manual.

This appears to be a well put together little booklet and a "must have" for anyone considering working on his own PI system

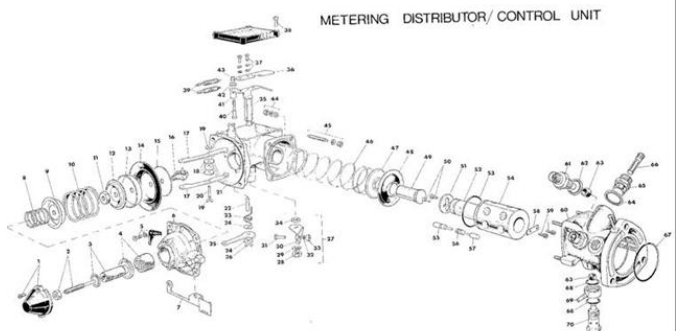
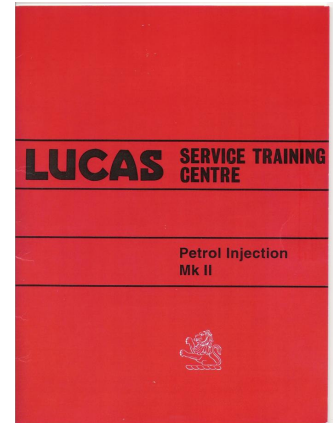

Spares for your Triumph from the club

René de Villiers (located in Gauteng) is the TSCC official spares buyer. He purchases spares for all Triumph models through Moss who has thousands of spares on their website. The TSCC is not in a business to make a profit and will thus only charge you the landed cost and a small margin for finance fees. If anyone wanted spares they should send him a fax or e-mail and he will get back to them with a quotation in 2-3 days. The quotation includes freight and duty. Orders take about a month to arrive and the cut off date each month is around the 10th. Spares can then be sent cheaply through the Post Office delivery systems to Cape Town. Rene's telephone numbers as follows: (h) 011-680-3124 or 083-317-4339. He will also have an email address shortly and we will keep you posted on progress made.

TRIADS

- Nick Joubert is selling his 1957 TR3, red with black soft top and an asking price of R80000. For more information call Nick on 083 263 3212 or e-mail at nic@agsprayers.co.za. See the website (www.capetriumph.za.org) triads for more pictures.



- Jon Rademan has decided to sell his LHD black TR7 SPIDER special edition (ex Ken Boss). This Triumph was specially built for the USA Californian market equipped with aircon. Jon has fitted new tyres, exhaust system and wiring etc – asking price R60 000. For more information contact Jon Rademan on 041 581 5038 or cell 082 569 2080.
- Heinz Koncki has also decided to sell his beautifully restored 1965 TR4A. This metallic blue Triumph with silver surrey top, mohair soft top, leather seats and spoke wheels has had a nut and bolt restoration with many upgrades. It has twice won a silver medal in the Concourse d'Elegance (Nationals 2004 & 2006). It has also twice won a gold medal in the Concourse d'Elegance (Nationals 2008 & 2010). Included in the documentation is a build certificate from the British Motor Heritage Trust and a photographic record of the restoration. For a more comprehensive list and pictures, visit the PE TSCC website at <http://www.tscepe.co.za/memberecars/heinz/heinz.htm>. Asking price R200.000 neg for more information contact Heinrich Koncki on 044 873 5250 or cell 079 625 0240 or email h.koncki@gmail.com.
- Ian Hauptfleisch is looking for a new garage for his TR3A, the owner of his current one is in the process of selling it. Please if any one has access to one or knows of any thing that may be available, please let Ian know on his website www.ccsulf.com, thanks in advance!
- Wilhelm Cool before emigrating to New Zealand has various garage tools and woodworking tools to sell. He already created some interest at the last noggin but has plenty left. For details call Wilhelm on 082 880 6018 or e-mail jcool@absamail.co.za

HEARD AROUND TOWN

- The thrust washer problem on my TR6 has been cured by Rod Mitchell. He dropped the sump and put oversize thrust washers ordered from Peter Flowers, problem solved! The thrust is well within limits and all seems well with the engine.

- After mine came out the next patient was Tom Dougan's TR6. This was due to hooting as he went round corners and a whine from the rear end. The hooting was cured by replacing the bushes in the steering column so there was no lateral play, the whine was traced to needing to tighten up the collapsible washers on the rear drive shafts, problem solved!
- The next car in Rod's workshop is Peter du Sautoy's TR5 to sort out his fuel injection problems. A few horrors were discovered in the fuel return system, Rod is now sorting out the injectors which were supposed to have been serviced when the engine was rebuilt. I joked with Rod, who is a major Alfa fan, that at last his workshop had a touch of class with all the Triumphs in it!
- While a TR5 and TR6 were very hot at the roadside on the N1 after the April noggin, Margaret Young and Nic Paxinos drove the same route in 'Ricky' the Triumph Herald which by the way behaved impeccably on the 90 minute journey.....so the sports car boys were upstaged by a little old lady tootling along in her Herald!!! Well done Margaret.
- Margaret also reports having seen Clive and Heletia Oosthuizen who will be remembered by some of our older members. Clive is successfully recovering from a heart attack and we wish them both well.
- Good to see that Danie Barkhuisen is well on the road to recovery when he came to see us off from the Engen.
- Peter and Monica du Sautoy will be travelling to the USA later this year, via Europe. They recently received notification of the TR Register organised TR European Meeting (17 – 19 Sept 2010) and Tour (19 – 25 Sept) to be held in Harrogate and are thus looking into whether they can change their itinerary to include this on the way.



TSCC Committee members 2010

Your Committee would like to hear your views and ideas at any time. Please feel free to contact us.

Chair	Tom Dougan	072 913 2392	tom.dougan10@gmail.com
Treasurer	Anne Dougan	079 438 2619	tom.dougan10@gmail.com
Editor	Jamie Hart	084 220 0082	jamie.hart@kingsley.co.za
Spares	Alan Sheard	082 257 2635	
Committee	Ronan Sanderson	082 443 3704	ronan.sanderson@gsb.uct.ac.za
Committee	Neil Cameron	082 323 9999	tigger@lantic.net
Regalia	Gidion Snyman	076 427 6854	snymangidion@xsinet.co.za
Clubhouse	Theo Brand	083 320 4820	

TRIUMPH CLUB POSTAL ADDRESS – P.O. Box 12197, N1 City, 7463
WEBSITE - www.capetriumph.za.org